

# FEATURES & BENEFITS

## MAXIMUM EFFICIENCY

With up to 157lm/W, the MINERGIE-certified ECO B office floor lamp is one of the most energy-efficient workplace lighting products available on the market. With a net luminous flux of over 12950lm, two- or four-person workstations can be illuminated, with the maximum connected wattage required amounting to 82.5W. ECO B is also available as a variant with just one light field for use with single-person desks.

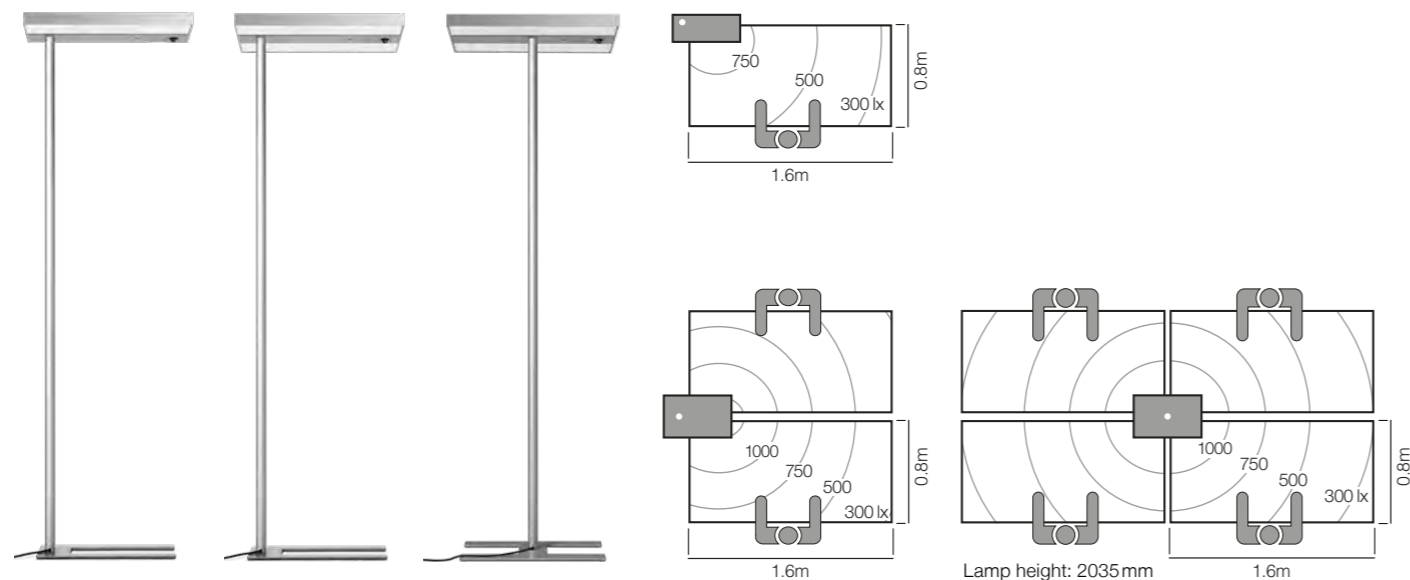

## SENSONIC LIGHT CONTROL SYSTEM

If it is used inefficiently, even the most efficient technology only offers limited added value. This is precisely why the ECO B floor lamp is equipped with the presence and ambient light-dependent SENSONIC control system, which provides optimum light conditions in the room in a fully automatic manner. The required luminous intensity is continuously adjusted to the available ambient light. The adjustable presence sensor detects even the smallest of movements in the detection range, ensuring that the lighting control system is optimised for the user.

In addition to the standard function, the control system can also be operated in semi-automatic mode. In semi-automatic mode, the floor lamp does not switch on autonomously; rather, it has to be deliberately switched on by the user. This prevents the lamp from switching on automatically if someone only enters a room for a short while, and also saves energy.

